



DOE CE CB



ZHEJIANG KAIMEI CATERING EQUIPMENT CO., LTD.
www.hzcamay.com



COMPANY INTRODUCTION

Zhejiang Kaimei Catering Equipment Co., Ltd. Branded CAMAY, located in Huzhou city belonging to the one-hour economic circle of Shanghai owning workshop with area of 45,000 square meters and more than 300 skilled employees, has been serving global partners since the year of 2010. Annually, CAMAY provides at least 300,000.00 units of commercial refrigeration equipment for global partners

As a professional manufacturer & exporter engaged in the R & D and production of commercial freezers, kitchen refrigerators, ice machines and display cabinets etc., our company is verified by the ISO9001:2015 management system certification and products are with various certifications such as CCC, ETL, CE, DOE, CEC, ENERGYSTAR, PSE, KC, CB and so on, which could fulfill need of partners worldwide.

We will be committed to maintaining and accelerating the cause of human health, providing partners with excellent benefit and value with professionalism and efficiency, also obtain double harvests of economic and social benefits.

WORKSHOP



DOE

CE

CB



REACH-IN

REFRIGERATOR / FREEZER



MR-23
MF-23



MR-49
MF-49



MR-83
MF-83

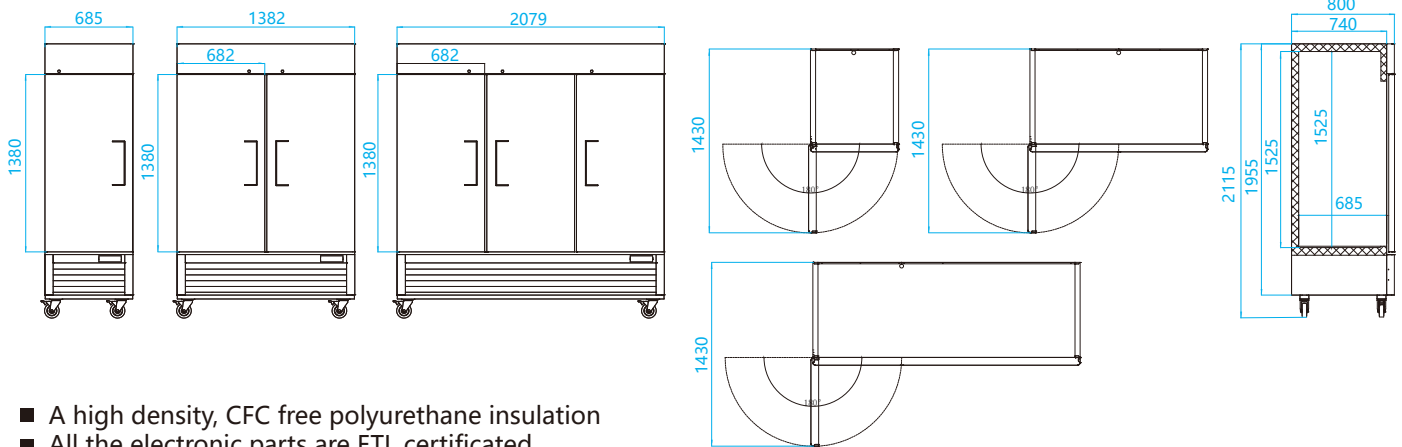

- A high density, CFC free polyurethane insulation
- All the electronic parts are ETL certified

MODEL	MR-23	MF-23	MR-49	MF-49	MR-83	MF-83
Classification	Refrigerator	Freezer	Refrigerator	Freezer	Refrigerator	Freezer
Cabinet dimension (WxDxH mm)	685*800*2115	685*800*2115	1382*800*2115	1382*800*2115	2079*800*2115	2079*800*2115
Cabinet dimension (WxDxH mm)	27 *31 ^{1/2} *83 ^{1/4}	27 *31 ^{1/2} *83 ^{1/4}	54 ^{1/2} *31 ^{1/2} *83 ^{1/4}	54 ^{1/2} *31 ^{1/2} *83 ^{1/4}	81 ^{3/4} *31 ^{1/2} *83 ^{1/4}	81 ^{3/4} *31 ^{1/2} *83 ^{1/4}
Capacity (L/Cuft)	547/19.32	547/19.32	1252/44.21	1252/44.21	1711/60.42	1711/60.42
Inner Temperature (°F)	33~41	-13~-5	33~41	-13~-5	33~41	-13~-5
Refrigerant	R290					
Insulation Type	Polyurethane / Cyclopentane + CFC Free					
Amps (A)	1.5	2.6	3	5.2	3.2	7.2
Voltage (V/Hz)	115/60					
Weight (Kg)	115	120	190	198	260	285
Power (W)	173	299	345	598	368	828
#of doors	1	1	2	2	3	3

REACH-IN

REFRIGERATOR / FREEZER

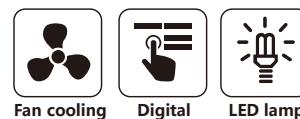

MR-23G
MF-23G



MR-49G
MF-49G



MR-83G
MF-83G

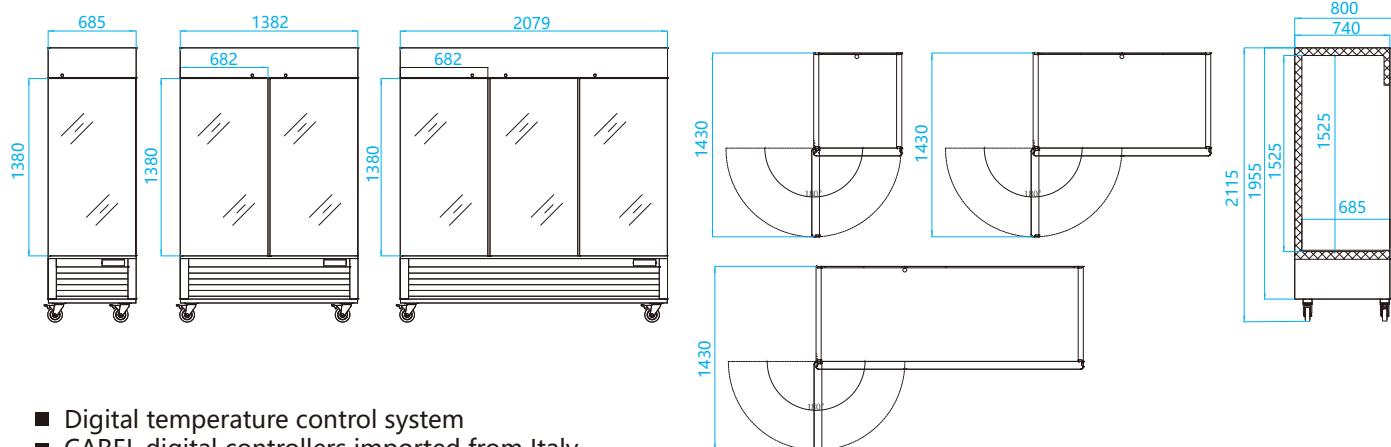

- Digital temperature control system
- CAREL digital controllers imported from Italy

MODEL	MR-23G	MF-23G	MR-49G	MF-49G	MR-83G	MF-83G
Classification	Refrigerator	Freezer	Refrigerator	Freezer	Refrigerator	Freezer
Cabinet dimension (WxDxH mm)	685*800*2115	685*800*2115	1382*800*2115	1382*800*2115	2079*800*2115	2079*800*2115
Cabinet dimension (WxDxH mm)	27 ^{1/2} *31 ^{1/2} *83 ^{1/4}	27 ^{1/2} *31 ^{1/2} *83 ^{1/4}	54 ^{1/2} *31 ^{1/2} *83 ^{1/4}	54 ^{1/2} *31 ^{1/2} *83 ^{1/4}	81 ^{3/4} *31 ^{1/2} *83 ^{1/4}	81 ^{3/4} *31 ^{1/2} *83 ^{1/4}
Capacity (L/Cuft)	547/19.32	547/19.32	1252/44.21	1252/44.21	1711/60.42	1711/60.42
Inner Temperature (°F)	33~41	-13~-5	33~41	-13~-5	33~41	-13~-5
Refrigerant	R290					
Insulation Type	Polyurethane / Cyclopentane + CFC Free					
Amps (A)	1.5	2.6	3	5.2	3.2	7.2
Voltage (V/Hz)	115/60					
Weight (Kg)	115	120	190	198	260	285
Power (W)	173	299	345	598	368	828
#of doors	1	1	2	2	3	3

REACH-IN GLASS DOOR WITH LED PANNEL

REFRIGERATOR / FREEZER



Fan cooling



Digital



LED lamp

MPR-23G
MPF-23G



MPR-49G
MPF-49G



MPR-83G
MPF-83G

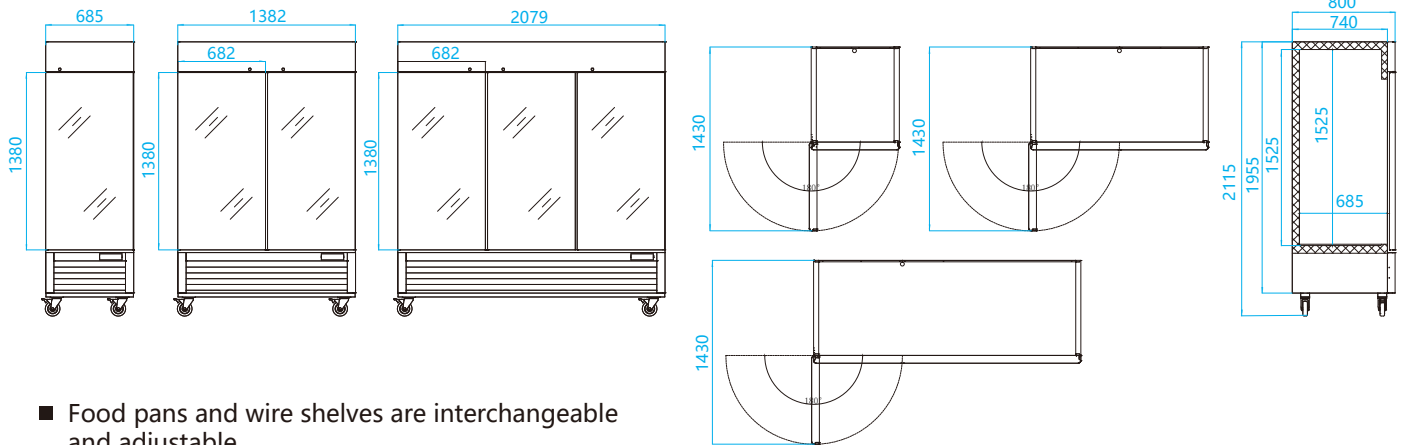

- Food pans and wire shelves are interchangeable and adjustable

MODEL	MPR-23G	MPF-23G	MPR-49G	MPF-49G	MPR-83G	MPF-83G
Classification	Refrigerator	Freezer	Refrigerator	Freezer	Refrigerator	Freezer
Cabinet dimension (WxDxH mm)	685*800*2115	685*800*2115	1382*800*2115	1382*800*2115	2079*800*2115	2079*800*2115
Cabinet dimension (WxDxH mm)	27 ^{1/2} *31 ^{1/2} *83 ^{1/4}	27 ^{1/2} *31 ^{1/2} *83 ^{1/4}	54 ^{1/2} *31 ^{1/2} *83 ^{1/4}	54 ^{1/2} *31 ^{1/2} *83 ^{1/4}	81 ^{3/4} *31 ^{1/2} *83 ^{1/4}	81 ^{3/4} *31 ^{1/2} *83 ^{1/4}
Capacity (L/Cuft)	547/19.32	547/19.32	1252/44.21	1252/44.21	1711/60.42	1711/60.42
Inner Temperature (°F)	33~41	-13~-5	33~41	-13~-5	33~41	-13~-5
Refrigerant	R290					
Insulation Type	Polyurethane / Cyclopentane + CFC Free					
Amps (A)	1.5	2.6	3	5.2	3.2	7.2
Voltage (V/Hz)	115/60					
Weight (Kg)	115	120	190	198	260	285
Power (W)	173	299	345	598	368	828
#of doors	1	1	2	2	3	3

UNDER COUNTER REFRIGERATOR / FREEZER

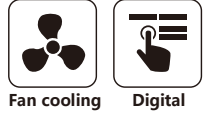

MTR-27
MTF-27

MTR-48 / MTR-60
MTF-48 / MTF-60

MTR-72
MTF-72

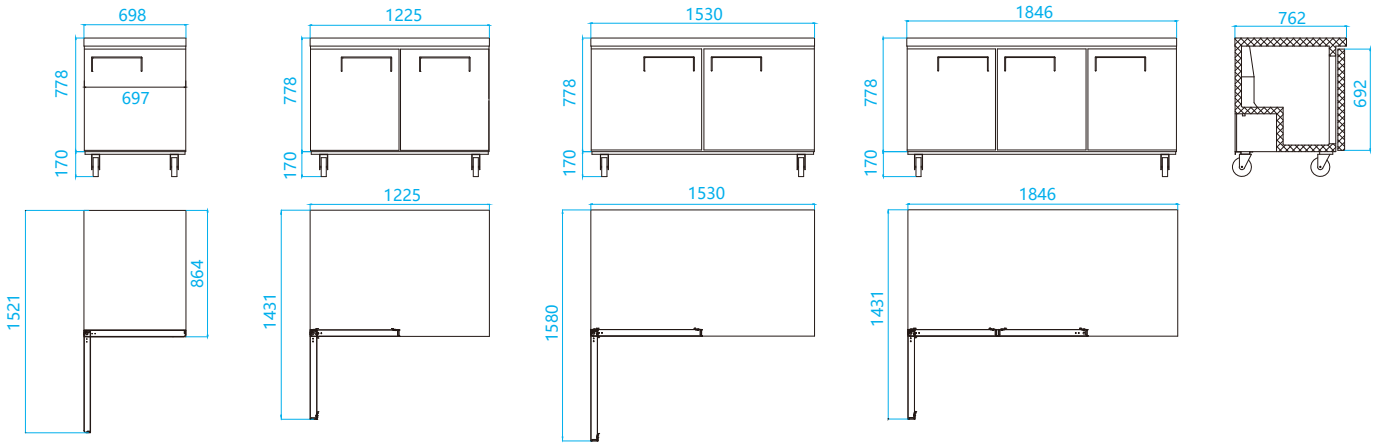

- High efficient compressor brand name Cubigel
- Ventilated refrigeration system with fast cooling speed
- Automatic on-off interior lighting and evaporator fan

MODEL	MTR-27	MTF-27	MTR-48	MTF-48	MTR-60	MTF-60	MTR-72	MTF-72
Classification	Refrigerator	Freezer	Refrigerator	Freezer	Refrigerator	Freezer	Refrigerator	Freezer
Cabinet dimension (WxDxH mm)	698*762*929	698*762*929	1225*762*929	1225*762*929	1530*762*929	1530*762*929	1846*762*929	1846*762*929
Cabinet dimension (WxDxH inch)	27 ^{1/2} *30*36 ^{1/2}	27 ^{1/2} *30*36 ^{1/2}	44 ^{1/3} *30*36 ^{1/2}	33 ^{1/3} *30*36 ^{1/2}	60 ^{1/3} *30*36 ^{1/2}	60 ^{1/3} *30*36 ^{1/2}	72 ^{1/2} *30*36 ^{1/2}	72 ^{1/2} *30*36 ^{1/2}
Capacity (L/Cuft)	202/7.13	202/7.13	368/13	368/13	476/16.81	476/16.81	576/20.34	576/20.34
Inner Temperature (°F)	33~41	-13~-5	33~41	-13~-5	33~41	-13~-5	33~41	-13~-5
Refrigerant	R290							
Insulation Type	Polyurethane / Cyclopentane + CFC Free							
Amps (A)	1.5	1.6	1.7	2.3	1.9	3	2	4.2
Voltage (V/Hz)	115/60							
Weight (Kg)	58	58	78	82	90	94	107	111
Power (W)	173	184	196	265	219	345	230	483
#of doors	1	1	2	2	2	2	3	3

SALAD SIDE PREP TABLE

REFRIGERATOR / FREEZER

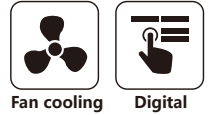

MSR-27M
MSR-27



MSR-48M / MSR-60M
MSR-48 / MSR-60



MSR-72M
MSR-72

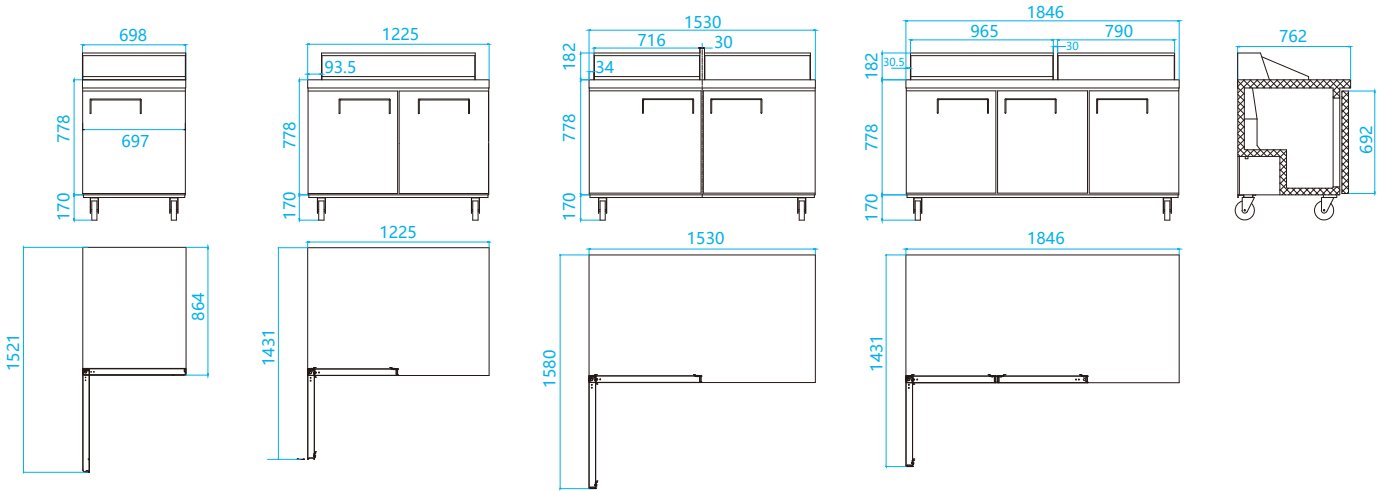

- Self-closing and stay open door
- Door lock

MODEL	MSR-27M	MSR-27	MSR-48M	MSR-48	MSR-60M	MSR-60	MSR-72M	MSR-72
Classification	Refrigerator	Refrigerator	Refrigerator	Refrigerator	Refrigerator	Refrigerator	Refrigerator	Refrigerator
Cabinet dimension (WxDxH mm)	698*762*1109	698*863*1181	1225*762*1109	1225*863*1181	1530*762*1109	1530*863*1181	1846*762*1109	1846*863*1181
Cabinet dimension (WxDxH inch)	27 ^{1/2} *30 *43 ^{1/2}	27 ^{1/2} *34 *46 ^{1/2}	44 ^{1/3} *30 *43 ^{1/2}	44 ^{1/3} *34 *46 ^{1/2}	60 ^{1/3} *30 *43 ^{1/2}	60 ^{1/3} *34 *46 ^{1/2}	72 ^{1/2} *30 *43 ^{1/2}	72 ^{1/2} *34 *46 ^{1/2}
Capacity (L/Cuft)	202/7.13	202/7.13	368/13	368/13	476/16.81	476/16.81	576/20.34	576/20.34
Inner Temperature (°F)	33~41	33~41	33~41	33~41	33~41	33~41	33~41	33~41
Refrigerant	R290							
Insulation Type	Polyurethane / Cyclopentane + CFC Free							
Amps (A)	1.8	1.8	1.8	1.8	2.9	2.9	3.2	3.2
Voltage (V/Hz)	115/60							
Weight (Kg)	67	68	95	96	112	114	134	137
Power (W)	207	207	207	207	334	334	368	368
#of doors	1	1	2	2	2	2	3	3

Professional One-Stop-Shop Refrigeration
Equipments Manufacturer 

ZHEJIANG KAIMEI CATERING EQUIPMENT CO., LTD.

Address: No.1 Xingnan Road, Nanshe Industrial Park, Zhongguan Town,
Deqing County, Huzhou City, Zhejiang Province, China

Email: sales@hzcamay.com